



SMV Air Suspension

Fiat Ducato

Peugeot Boxer

Citroen Jumper

Typ 230/244/x250

Zusatzluftfederung Z6 / Z8

SMV AG

Grabenstrasse 2

CH – 9320 Arbon

Phone: 0041 (0) 71 440 04 88

Fax: 0041 (0) 71 440 04 89

E-Mail: info@smvag.ch





Fiat Ducato
Peugeot Boxer
Citroen Jumper

Typ 230/244/x250

Zusatzluftfederung Z6 / Z8

1. Preface

This additional air suspension system was developed specifically for Fiat Ducato, Peugeot Boxer and Citroen Jumper RVs. Before you start, please read this manual to prevent installation errors. All needed parts are fully included.

The installation must be performed by a professional mechanic. We are not liable for mistakes or defects due to improper installation. The warranty does not cover the last-mentioned point.

This air suspension is only applicable for motorhomes and chassis with a minimum rear axle load of 1550 Kg

Index

- | | |
|-----------------------------|----|
| • preface | 2 |
| • installation instructions | 3 |
| • postface | 13 |



Fiat Ducato
Peugeot Boxer
Citroen Jumper

Typ 230/244/x250

Zusatzluftfederung Z6 / Z8

2. Preparing for installation

- 2.1 Remove the standard mounted stop absorber (Pic1 & Pic 2) and the bracket (Pic. 3 and 4)



- 2.2 Mount the air bellow by screwing the upper-end of the bellow into the thread of the original stop absorber. **(Pic 1)**
Make sure that the lower plate fits the flat spring as shown on Sketch 1.1 / 2 or 2.1 / 2 (if necessary turn the bellow in the correct position).

Fiat Ducato
 Peugeot Boxer
 Citroen Jumper

Typ 230/244/x250

Zusatzluftfederung Z6 / Z8

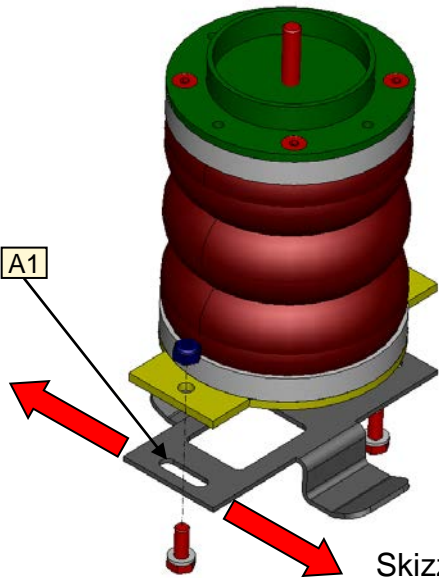

Skizze 2.1

Skizze 2.2

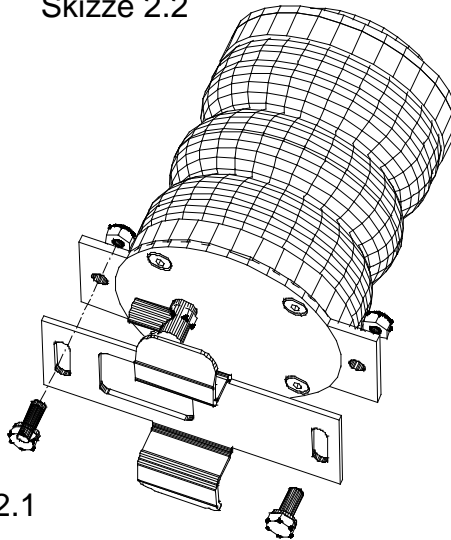

By using a slot (see A1) the plate can be moved.

This ensures a vertical load of the spring.

2.3

Now turn the connection of the bellow so that it shows on the opposite one. (Pos 1 or Pos 2). Now connect the supplied vacuum hose to the air bellows by plugging it with some pressure and movement to the elbow union, than tighten the nut.

Proceed as described above for second bellow.



Bild 5



2.4

Put the brackets back to where they were and screw them back with the original nuts.

Fiat Ducato
Peugeot Boxer
Citroen Jumper

Typ 230/244/x250

Zusatzluftfederung Z6 / Z8

- 2.5 Now remove the panel on the seat of the driver seats (Pic. 6 and 7) and the hand brake (Pic. 8).



- 2.6 As shown on picture 9 and 10 drill the holes for the valves D = 10 mm and the manometer D = 40 mm. Insert the valves and manometer and screw them. Use additional thread lock fluid. (e.g. Loctite).





Fiat Ducato
Peugeot Boxer
Citroen Jumper

Typ 230/244/x250

Zusatzluftfederung Z6 / Z8

- 2.7 Now install the air hoses from the air bags up into the cab. Install the cables to the valves and pressure gauges and close them as the air springs on.

The pipe should be protected against

- heat from the exhaust
- splashing dirt
- foreign object damage (such as branches etc.)

Caution!: If the air hose is too long, it can be cut.

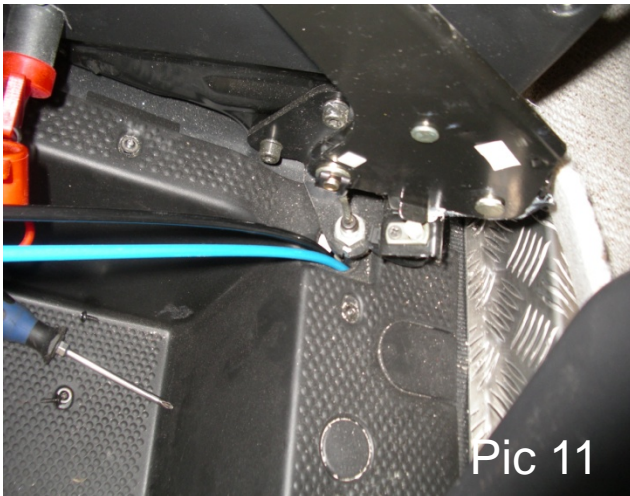



Fiat Ducato
Peugeot Boxer
Citroen Jumper

Typ 230/244/x250

Zusatzluftfederung Z6 / Z8

Operation

Using a normal car tire pump you can control the pressure in the air bellows. When inflating, you should pay attention to the level of the vehicle. This should be slightly forward. If the car gets too high, you can reduce the pressure.

Important

Z6/Z8 - minimum pressure is 1 bar

Z6 - maximum pressure is 5 bar

Z8 - maximum pressure is 7 bar

Depending on the load the right or left side needs more or less pressure, so that the vehicle is in an balanced position.

Maintenance

Generally the air suspension does not need any maintenance. The casually control of the air pressure is sufficient.
If you wash your car, remove dirt etc. from pipes and bellows.

Fiat Ducato
Peugeot Boxer
Citroen Jumper

Typ 230/244/x250

Zusatzluftfederung Z6 / Z8

1. upper palte
2. uripple bellow 130/3
3. bottom plate
4. countersunk bolt M6 x 16

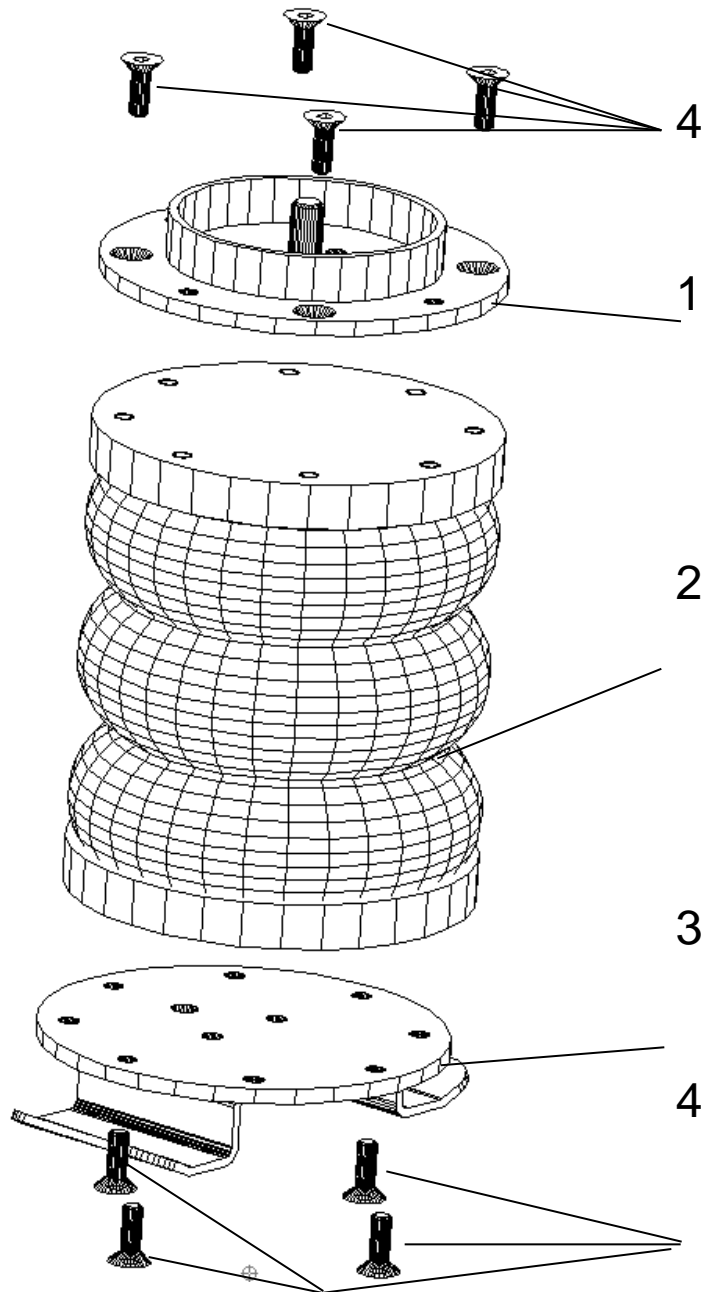

exploded assembly drawing of the air suspension



SMV AG - Grabenstrasse 2 - CH-9320 Arbon

Fiat Ducato
Peugeot Boxer
Citroen Jumper

Typ 230/244/x250

Zusatzluftfederung Z6 / Z8

Air suspension kit with A.B.S.

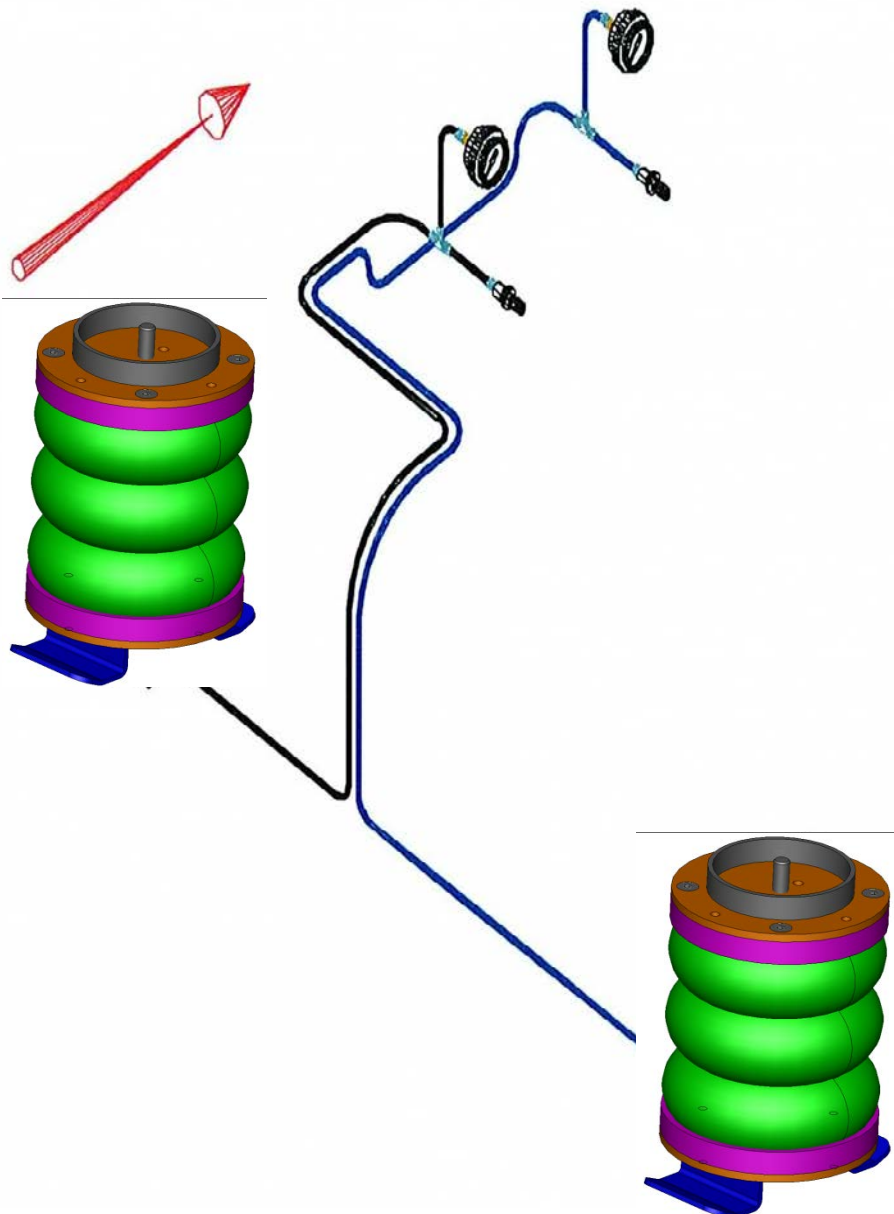



SMV AG - Grabenstrasse 2 - CH-9320 Arbon

Fiat Ducato
Peugeot Boxer
Citroen Jumper

Typ 230/244/x250

Zusatzluftfederung Z6 / Z8

Air suspension kit without A.B.S

(Additional linkage is not included within the scope of supply.)

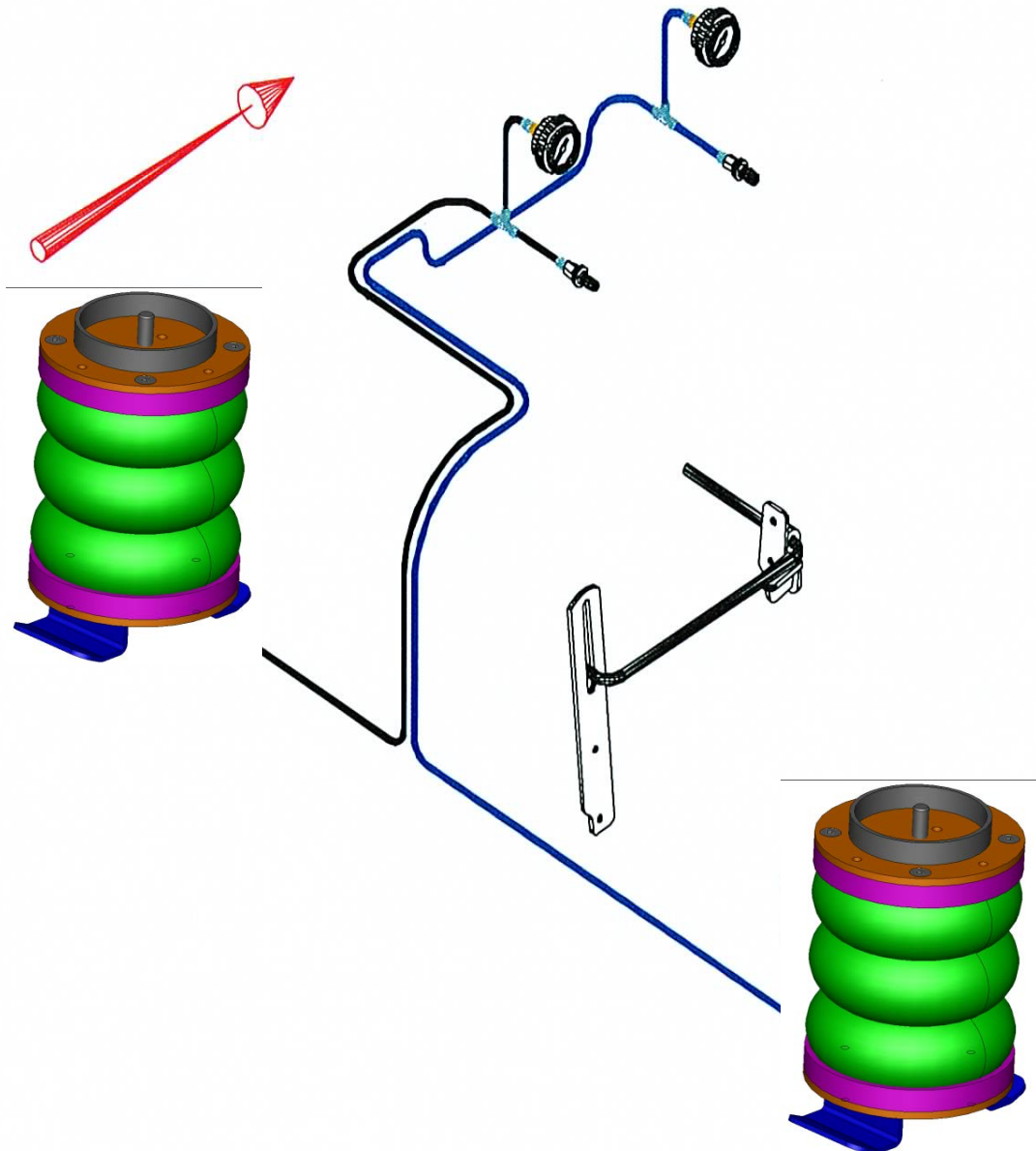

Fiat Ducato
Peugeot Boxer
Citroen Jumper

Typ 230/244/x250

Zusatzluftfederung Z6 / Z8

2.8 Only for vehicules without ABS

(Fiat 230)

Installation of the additional linkage
on the load-dependent braking force regulator.

(see pic. 12) Remove the connecting link between adjusting linkage and torsion bar by pulling it up to remove the rod from the linkage. Install the additional linkage to the original linkage by pressing the bolt with previously attached spacer into the upper bearing of the original linkage, place the washer, insert the cotter pin and bend apart. Set the torsion bar into the hole of the additional linkage and screw both with the little flange and the self-locking nuts.

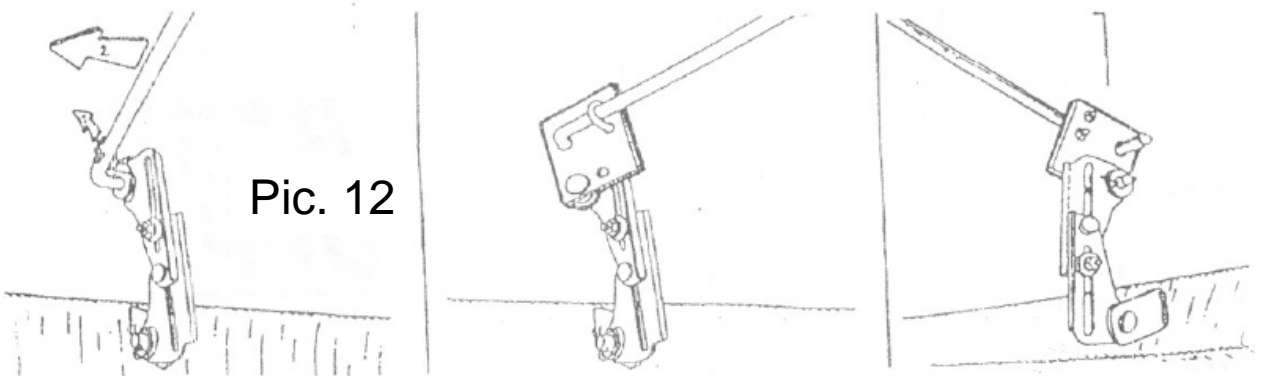

Pic. 12

- Fiat 244: Can be adjusted on the existing linkage.
No additional braking force regulator required.

Important: The additional linkage is not included within the scope of supply and has to be purchased separately.



Fiat Ducato
Peugeot Boxer
Citroen Jumper

Typ 230/244/x250

Zusatzluftfederung Z6 / Z8

3. Postface

SMV - Metal wishes you the best advantages with this additional air suspension system. For the system to work properly, we recommend that you consistently check for any irregularities.

Furthermore the system needs to be cleaned regularly. If you wash your car, remove dirt etc. from pipes and bellows.

If you have any questions please do not hesitate to call us or your local dealer.

SMV Service Hotline: 0049 – (0)5471 – 9583 - 0